

MONTREAL - WITH HYBRID MIST BURNER

MONTREAL 800 mm - Tunnel - Hybrid Mist

This refined Montreal built-in fireplace, with an open front and back and two low glass panels, is fitted with the innovative Hybrid Mist burner. The mist is illuminated by LEDs on both sides of the burner, enhancing the natural flame effect. It adds gentle humidity to the room, improving comfort and indoor air quality. Designed and produced in Denmark. Ideal as a stylish focal point for modern interiors.



OPERATION

The model is equipped with an electronic bio burner and can be operated either with the included remote control, via the control panel on the burner or the DecoFlame App, available for both Android and Apple.

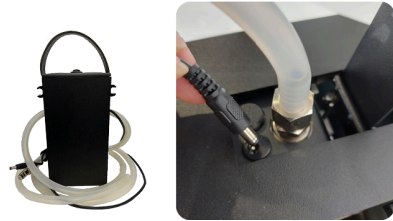
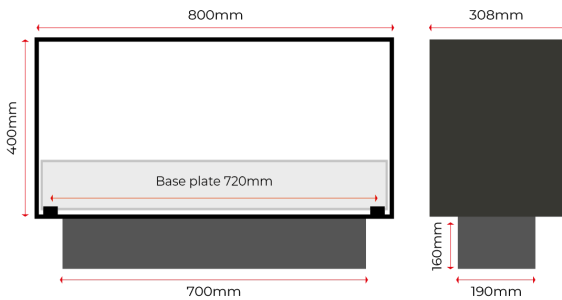

ELECTRONIC PUMP

Included: External customised filling pump for safe and easy filling. Can also be used if the tank needs to be emptied.

GENERAL INFORMATION

Model	Montreal 800 mm
Configuration	Open to Front and Back vs 2
Included Burner	Hybrid Mist 720
Operation Type	Electronic
Production	Made in Denmark

DESIGN & MATERIALS

Material	Stainless steel / Powder coated aluminum
Finish	Standard black powder coating
Glass Quality	Tempered diamond clear glass
Standard Glass	2x Low Glass

MONTREAL - WITH HYBRID MIST BURNER**PHYSICAL SPECIFICATIONS**

Gross Dimensions (mm)	W: 800 × H: 400 × D: 308
Glass Dimensions (mm)	Low Glass: L: 769 × H: 110 × T: 10 / L: 271 × H: 110 × T: 10
Weight: (kg)	32.0

BURNER DETAILS

Burner Model	Hybrid Mist 720
Fuel Type	Demineralised water
Flametray (mm)	
Flame Levels	6
Chimney	Not Required

PERFORMANCE

Capacity (L)	6.0
Max Level Burn Time (H)	48.0
Nominal Heat Output (kW)	N/A
Fuel consumption (ml/h)	125

INSTALLATION REQUIREMENTS

Cut-out Dimensions (mm)	W: 810 × H: 410 × D: 308
Minimum Room Size (m ³)	N/A
Power Supply	230 V AC (220 V compatible), 50–60 Hz, earthed connection
Installation Environment	Indoor

FEATURES

Safety Features	Flame level Indikator / Water level Indikator
Add-on Features	Glassdoor / Bronze glass / Ceramic Firewood / BWT Water filter / Automatic BWT Water filter
Included Features	Vapour / LED Technology / Remote Control / App Operation / Large Fuel Tank / External Fuel Pump with Quick Connection

DISCLAIMER – DECOFLAME A/S

All product specifications and technical data are subject to change without prior notice and are considered accurate as of the date of publication. Decoflame A/S, including its affiliates, employees, agents and other representatives (collectively referred to as "Decoflame A/S"), disclaims all liability for any errors, inaccuracies, or omissions in this document or in any other product-related information. Decoflame A/S shall not be held liable for any damage, loss, or indirect consequences arising from the use, installation, or operation of the products, unless otherwise required under applicable law. It is the user's responsibility to ensure correct installation and usage in accordance with applicable safety standards and the manufacturer's instructions. No licence, whether express or implied, to any intellectual property rights is granted through this document. Customers who use or sell Decoflame A/S products for purposes not explicitly specified do so at their own risk and agree to indemnify Decoflame A/S against any claims or damages resulting from such use. Fuel consumption may vary depending on individual units, environmental conditions, and operating parameters. Product images are for illustrative purposes only and may differ from the actual product. This limitation of liability does not apply where it would conflict with mandatory consumer protection laws.

MONTREAL - WITH HYBRID MIST BURNER

MONTREAL 1000 mm - Tunnel - Hybrid Mist

This refined Montreal built-in fireplace, with an open front and back and two low glass panels, is fitted with the innovative Hybrid Mist burner. The mist is illuminated by LEDs on both sides of the burner, enhancing the natural flame effect. It adds gentle humidity to the room, improving comfort and indoor air quality. Designed and produced in Denmark. Ideal as a stylish focal point for modern interiors.



OPERATION

The model is equipped with an electronic bio burner and can be operated either with the included remote control, via the control panel on the burner or the DecoFlame App, available for both Android and Apple.

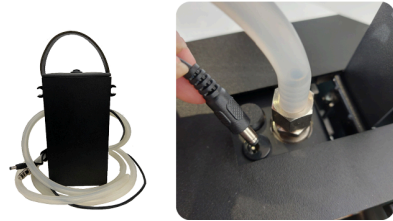
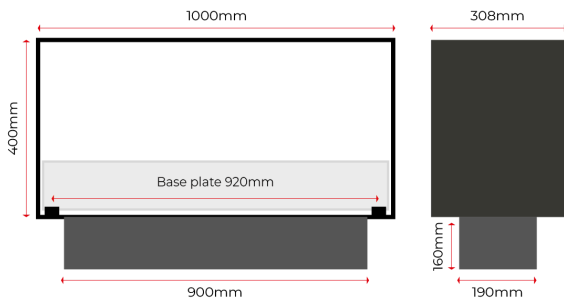

ELECTRONIC PUMP

Included: External customised filling pump for safe and easy filling. Can also be used if the tank needs to be emptied.

GENERAL INFORMATION

Model	Montreal 1000 mm
Configuration	Open to Front and Back vs 2
Included Burner	Hybrid Mist 920
Operation Type	Electronic
Production	Made in Denmark

DESIGN & MATERIALS

Material	Stainless steel / Powder coated aluminum
Finish	Standard black powder coating
Glass Quality	Tempered diamond clear glass
Standard Glass	2x Low Glass

MONTREAL - WITH HYBRID MIST BURNER**PHYSICAL SPECIFICATIONS**

Gross Dimensions (mm)	W: 1000 × H: 400 × D: 308
Glass Dimensions (mm)	Low Glass: L: 769 × H: 110 × T: 10 / L: 271 × H: 110 × T: 10
Weight: (kg)	39.0

BURNER DETAILS

Burner Model	Hybrid Mist 920
Fuel Type	Demineralised water
Flametray (mm)	
Flame Levels	6
Chimney	Not Required

PERFORMANCE

Capacity (L)	8.0
Max Level Burn Time (H)	53.0
Nominal Heat Output (kW)	N/A
Fuel consumption (ml/h)	150

INSTALLATION REQUIREMENTS

Cut-out Dimensions (mm)	W: 1010 × H: 410 × D: 308
Minimum Room Size (m ³)	N/A
Power Supply	230 V AC (220 V compatible), 50–60 Hz, earthed connection
Installation Environment	Indoor

FEATURES

Safety Features	Flame level Indikator / Water level Indikator
Add-on Features	Glassdoor / Bronze glass / Ceramic Firewood / BWT Water filter / Automatic BWT Water filter
Included Features	Vapour / LED Technology / Remote Control / App Operation / Large Fuel Tank / External Fuel Pump with Quick Connection

DISCLAIMER – DECOFLAME A/S

All product specifications and technical data are subject to change without prior notice and are considered accurate as of the date of publication. Decoflame A/S, including its affiliates, employees, agents and other representatives (collectively referred to as "Decoflame A/S"), disclaims all liability for any errors, inaccuracies, or omissions in this document or in any other product-related information. Decoflame A/S shall not be held liable for any damage, loss, or indirect consequences arising from the use, installation, or operation of the products, unless otherwise required under applicable law. It is the user's responsibility to ensure correct installation and usage in accordance with applicable safety standards and the manufacturer's instructions. No licence, whether express or implied, to any intellectual property rights is granted through this document. Customers who use or sell Decoflame A/S products for purposes not explicitly specified do so at their own risk and agree to indemnify Decoflame A/S against any claims or damages resulting from such use. Fuel consumption may vary depending on individual units, environmental conditions, and operating parameters. Product images are for illustrative purposes only and may differ from the actual product. This limitation of liability does not apply where it would conflict with mandatory consumer protection laws.

MONTREAL - WITH HYBRID MIST BURNER

MONTREAL 1200 mm - Tunnel - Hybrid Mist

This refined Montreal built-in fireplace, with an open front and back and two low glass panels, is fitted with the innovative Hybrid Mist burner. The mist is illuminated by LEDs on both sides of the burner, enhancing the natural flame effect. It adds gentle humidity to the room, improving comfort and indoor air quality. Designed and produced in Denmark. Ideal as a stylish focal point for modern interiors.



OPERATION

The model is equipped with an electronic bio burner and can be operated either with the included remote control, via the control panel on the burner or the DecoFlame App, available for both Android and Apple.

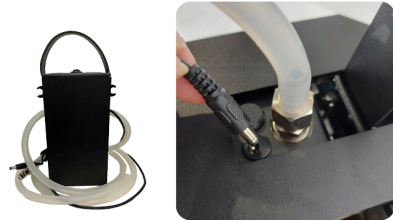
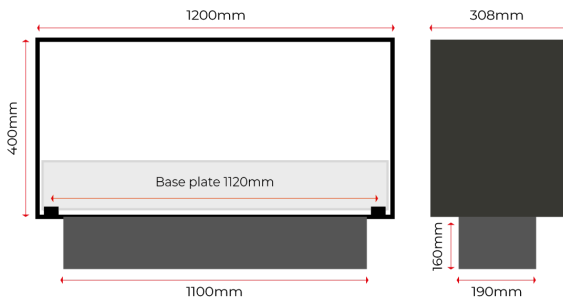

ELECTRONIC PUMP

Included: External customised filling pump for safe and easy filling. Can also be used if the tank needs to be emptied.

GENERAL INFORMATION

Model	Montreal 1200 mm
Configuration	Open to Front and Back vs 2
Included Burner	Hybrid Mist 1120
Operation Type	Electronic
Production	Made in Denmark

DESIGN & MATERIALS

Material	Stainless steel / Powder coated aluminum
Finish	Standard black powder coating
Glass Quality	Tempered diamond clear glass
Standard Glass	2x Low Glass

MONTREAL - WITH HYBRID MIST BURNER**PHYSICAL SPECIFICATIONS**

Gross Dimensions (mm)	W: 1200 × H: 400 × D: 308
Glass Dimensions (mm)	Low Glass: L: 769 × H: 110 × T: 10 / L: 271 × H: 110 × T: 10
Weight: (kg)	44.0

BURNER DETAILS

Burner Model	Hybrid Mist 1120
Fuel Type	Demineralised water
Flametray (mm)	
Flame Levels	6
Chimney	Not Required

PERFORMANCE

Capacity (L)	8.0
Max Level Burn Time (H)	53.0
Nominal Heat Output (kW)	N/A
Fuel consumption (ml/h)	150

INSTALLATION REQUIREMENTS

Cut-out Dimensions (mm)	W: 1210 × H: 410 × D: 308
Minimum Room Size (m ³)	N/A
Power Supply	230 V AC (220 V compatible), 50–60 Hz, earthed connection
Installation Environment	Indoor

FEATURES

Safety Features	Flame level Indikator / Water level Indikator
Add-on Features	Glassdoor / Bronze glass / Ceramic Firewood / BWT Water filter / Automatic BWT Water filter
Included Features	Vapour /LED Technology / Remote Control / App Operation / Large Fuel Tank / External Fuel Pump with Quick Connection

DISCLAIMER – DECOFLAME A/S

All product specifications and technical data are subject to change without prior notice and are considered accurate as of the date of publication. Decoflame A/S, including its affiliates, employees, agents and other representatives (collectively referred to as "Decoflame A/S"), disclaims all liability for any errors, inaccuracies, or omissions in this document or in any other product-related information. Decoflame A/S shall not be held liable for any damage, loss, or indirect consequences arising from the use, installation, or operation of the products, unless otherwise required under applicable law. It is the user's responsibility to ensure correct installation and usage in accordance with applicable safety standards and the manufacturer's instructions. No licence, whether express or implied, to any intellectual property rights is granted through this document. Customers who use or sell Decoflame A/S products for purposes not explicitly specified do so at their own risk and agree to indemnify Decoflame A/S against any claims or damages resulting from such use. Fuel consumption may vary depending on individual units, environmental conditions, and operating parameters. Product images are for illustrative purposes only and may differ from the actual product. This limitation of liability does not apply where it would conflict with mandatory consumer protection laws.

MONTREAL - WITH HYBRID MIST BURNER

MONTREAL 800 mm - Tunnel - Low/high Glass - Hybrid Mist

This elegant Montreal built-in fireplace, designed with an open front and back and one high and one low glass panel, features the innovative Hybrid Mist burner. It atomises water into fine mist and uses built-in LED lights to create the illusion of real flames. A beautiful solution for those who prefer a fireplace without heat and open flames. Designed and produced in Denmark. Ideal as a stylish focal point for modern interiors.



OPERATION

The model is equipped with an electronic bio burner and can be operated either with the included remote control, via the control panel on the burner or the DecoFlame App, available for both Android and Apple.

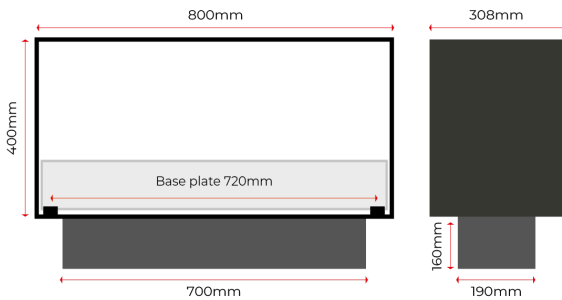

ELECTRONIC PUMP

Included: External customised filling pump for safe and easy filling. Can also be used if the tank needs to be emptied.

GENERAL INFORMATION

Model	Montreal 800 mm
Configuration	Open to Front and Back vs 1
Included Burner	Hybrid Mist 720
Operation Type	Electronic
Production	Made in Denmark

DESIGN & MATERIALS

Material	Stainless steel / Powder coated aluminum
Finish	Standard black powder coating
Glass Quality	Tempered diamond clear glass
Standard Glass	1x Low Glass / 1x High Glass

MONTREAL - WITH HYBRID MIST BURNER**PHYSICAL SPECIFICATIONS**

Gross Dimensions (mm)	W: 800 × H: 400 × D: 308
Glass Dimensions (mm)	Low Glass: L: 764 × H: 110 × T: 10 / High Glass: L: 764 × H: 362 × T: 10
Weight: (kg)	37.0

BURNER DETAILS

Burner Model	Hybrid Mist 720
Fuel Type	Demineralised water
Flametray (mm)	
Flame Levels	6
Chimney	Not Required

PERFORMANCE

Capacity (L)	6.0
Max Level Burn Time (H)	48.0
Nominal Heat Output (kW)	N/A
Fuel consumption (ml/h)	125

INSTALLATION REQUIREMENTS

Cut-out Dimensions (mm)	W: 810 × H: 410 × D: 308
Minimum Room Size (m ³)	N/A
Power Supply	230 V AC (220 V compatible), 50–60 Hz, earthed connection
Installation Environment	Indoor

FEATURES

Safety Features	Flame level Indikator / Water level Indikator
Add-on Features	Glassdoor / Bronze glass / Ceramic Firewood / BWT Water filter / Automatic BWT Water filter
Included Features	Vapour / LED Technology / Remote Control / App Operation / Large Fuel Tank / External Fuel Pump with Quick Connection

DISCLAIMER – DECOFLAME A/S

All product specifications and technical data are subject to change without prior notice and are considered accurate as of the date of publication. Decoflame A/S, including its affiliates, employees, agents and other representatives (collectively referred to as "Decoflame A/S"), disclaims all liability for any errors, inaccuracies, or omissions in this document or in any other product-related information. Decoflame A/S shall not be held liable for any damage, loss, or indirect consequences arising from the use, installation, or operation of the products, unless otherwise required under applicable law. It is the user's responsibility to ensure correct installation and usage in accordance with applicable safety standards and the manufacturer's instructions. No licence, whether express or implied, to any intellectual property rights is granted through this document. Customers who use or sell Decoflame A/S products for purposes not explicitly specified do so at their own risk and agree to indemnify Decoflame A/S against any claims or damages resulting from such use. Fuel consumption may vary depending on individual units, environmental conditions, and operating parameters. Product images are for illustrative purposes only and may differ from the actual product. This limitation of liability does not apply where it would conflict with mandatory consumer protection laws.

MONTREAL - WITH HYBRID MIST BURNER

MONTREAL 1000 mm - Tunnel - Low/high Glass - Hybrid Mist

This elegant Montreal built-in fireplace, designed with an open front and back and one high and one low glass panel, features the innovative Hybrid Mist burner. It atomises water into fine mist and uses built-in LED lights to create the illusion of real flames. A beautiful solution for those who prefer a fireplace without heat and open flames. Designed and produced in Denmark. Ideal as a stylish focal point for modern interiors.



OPERATION

The model is equipped with an electronic bio burner and can be operated either with the included remote control, via the control panel on the burner or the DecoFlame App, available for both Android and Apple.

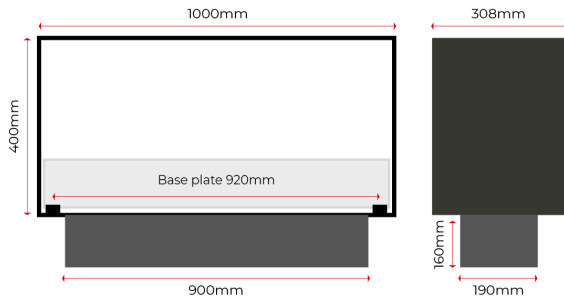

ELECTRONIC PUMP

Included: External customised filling pump for safe and easy filling. Can also be used if the tank needs to be emptied.

GENERAL INFORMATION

Model	Montreal 1000 mm
Configuration	Open to Front and Back vs 1
Included Burner	Hybrid Mist 920
Operation Type	Electronic
Production	Made in Denmark

DESIGN & MATERIALS

Material	Stainless steel / Powder coated aluminum
Finish	Standard black powder coating
Glass Quality	Tempered diamond clear glass
Standard Glass	1x Low Glass / 1x High Glass

MONTREAL - WITH HYBRID MIST BURNER**PHYSICAL SPECIFICATIONS**

Gross Dimensions (mm)	W: 1000 × H: 400 × D: 308
Glass Dimensions (mm)	Low Glass: L: 764 × H: 110 × T: 10 / High Glass: L: 764 × H: 362 × T: 10
Weight: (kg)	44.0

BURNER DETAILS

Burner Model	Hybrid Mist 920
Fuel Type	Demineralised water
Flametray (mm)	
Flame Levels	6
Chimney	Not Required

PERFORMANCE

Capacity (L)	8.0
Max Level Burn Time (H)	53.0
Nominal Heat Output (kW)	N/A
Fuel consumption (ml/h)	150

INSTALLATION REQUIREMENTS

Cut-out Dimensions (mm)	W: 1010 × H: 410 × D: 308
Minimum Room Size (m ³)	N/A
Power Supply	230 V AC (220 V compatible), 50–60 Hz, earthed connection
Installation Environment	Indoor

FEATURES

Safety Features	Flame level Indikator / Water level Indikator
Add-on Features	Glassdoor / Bronze glass / Ceramic Firewood / BWT Water filter / Automatic BWT Water filter
Included Features	Vapour / LED Technology / Remote Control / App Operation / Large Fuel Tank / External Fuel Pump with Quick Connection

DISCLAIMER – DECOFLAME A/S

All product specifications and technical data are subject to change without prior notice and are considered accurate as of the date of publication. Decoflame A/S, including its affiliates, employees, agents and other representatives (collectively referred to as "Decoflame A/S"), disclaims all liability for any errors, inaccuracies, or omissions in this document or in any other product-related information. Decoflame A/S shall not be held liable for any damage, loss, or indirect consequences arising from the use, installation, or operation of the products, unless otherwise required under applicable law. It is the user's responsibility to ensure correct installation and usage in accordance with applicable safety standards and the manufacturer's instructions. No licence, whether express or implied, to any intellectual property rights is granted through this document. Customers who use or sell Decoflame A/S products for purposes not explicitly specified do so at their own risk and agree to indemnify Decoflame A/S against any claims or damages resulting from such use. Fuel consumption may vary depending on individual units, environmental conditions, and operating parameters. Product images are for illustrative purposes only and may differ from the actual product. This limitation of liability does not apply where it would conflict with mandatory consumer protection laws.

MONTREAL - WITH HYBRID MIST BURNER

MONTREAL 1200 mm - Tunnel - Low/high Glass - Hybrid Mist

This elegant Montreal built-in fireplace, designed with an open front and back and one high and one low glass panel, features the innovative Hybrid Mist burner. It atomises water into fine mist and uses built-in LED lights to create the illusion of real flames. A beautiful solution for those who prefer a fireplace without heat and open flames. Designed and produced in Denmark. Ideal as a stylish focal point for modern interiors.



OPERATION

The model is equipped with an electronic bio burner and can be operated either with the included remote control, via the control panel on the burner or the DecoFlame App, available for both Android and Apple.

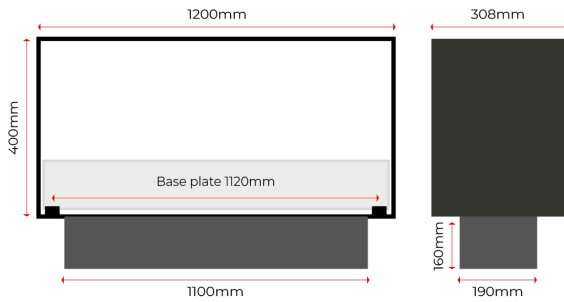

ELECTRONIC PUMP

Included: External customised filling pump for safe and easy filling. Can also be used if the tank needs to be emptied.

GENERAL INFORMATION

Model	Montreal 1200 mm
Configuration	Open to Front and Back vs 1
Included Burner	Hybrid Mist 1120
Operation Type	Electronic
Production	Made in Denmark

DESIGN & MATERIALS

Material	Stainless steel / Powder coated aluminum
Finish	Standard black powder coating
Glass Quality	Tempered diamond clear glass
Standard Glass	1x Low Glass / 1x High Glass

MONTREAL - WITH HYBRID MIST BURNER**PHYSICAL SPECIFICATIONS**

Gross Dimensions (mm)	W: 1200 × H: 400 × D: 308
Glass Dimensions (mm)	Low Glass: L: 764 × H: 110 × T: 10 / High Glass: L: 764 × H: 362 × T: 10
Weight: (kg)	52.0

BURNER DETAILS

Burner Model	Hybrid Mist 1120
Fuel Type	Demineralised water
Flametray (mm)	
Flame Levels	6
Chimney	Not Required

PERFORMANCE

Capacity (L)	8.0
Max Level Burn Time (H)	53.0
Nominal Heat Output (kW)	N/A
Fuel consumption (ml/h)	150

INSTALLATION REQUIREMENTS

Cut-out Dimensions (mm)	W: 1210 × H: 410 × D: 308
Minimum Room Size (m ³)	N/A
Power Supply	230 V AC (220 V compatible), 50–60 Hz, earthed connection
Installation Environment	Indoor

FEATURES

Safety Features	Flame level Indikator / Water level Indikator
Add-on Features	Glassdoor / Bronze glass / Ceramic Firewood / BWT Water filter / Automatic BWT Water filter
Included Features	Vapour /LED Technology / Remote Control / App Operation / Large Fuel Tank / External Fuel Pump with Quick Connection

DISCLAIMER – DECOFLAME A/S

All product specifications and technical data are subject to change without prior notice and are considered accurate as of the date of publication. Decoflame A/S, including its affiliates, employees, agents and other representatives (collectively referred to as "Decoflame A/S"), disclaims all liability for any errors, inaccuracies, or omissions in this document or in any other product-related information. Decoflame A/S shall not be held liable for any damage, loss, or indirect consequences arising from the use, installation, or operation of the products, unless otherwise required under applicable law. It is the user's responsibility to ensure correct installation and usage in accordance with applicable safety standards and the manufacturer's instructions. No licence, whether express or implied, to any intellectual property rights is granted through this document. Customers who use or sell Decoflame A/S products for purposes not explicitly specified do so at their own risk and agree to indemnify Decoflame A/S against any claims or damages resulting from such use. Fuel consumption may vary depending on individual units, environmental conditions, and operating parameters. Product images are for illustrative purposes only and may differ from the actual product. This limitation of liability does not apply where it would conflict with mandatory consumer protection laws.